

FEATURES :

- High torsional stiffness
- Higher resistance to bending moments
- Minimal friction error
- Low end sensitivity due to absence of moving parts

Safety Considerations: "It would be unsafe to operate Lebow® Torque Sensors and Load Cells beyond static overload or ultimate extraneous load limits as defined in the glossary of terms or, when applicable, higher than maximum speed. When in doubt, consult the factory. Lebow® Products is not responsible for any property damage or personal injury which may result because of the misapplication of the Transducer."

PERFORMANCE SPECS :
2110-2116 AND 2320-2404

SPECIFICATIONS

Actual performance average:

Nonlinearity:	0.026%
Hysteresis:	0.029%
Nonlinearity: of rated output	± 0.1%
Hysteresis: of rated output	± 0.1%
Output at rated capacity:* millivolts per volt, nominal	2
Repeatability: of rated output	± 0.05%
Zero balance: of rated output	± 1.0%
Bridge resistance: ohms nominal	350*
Temperature range, compensated: °F	+70 to +170
Temperature range, compensated: °C	+21 to +77
Temperature range, usable: °F	-65 to +200
Temperature range, usable: °C	-54 to +93
Temperature effect on output: of reading per °F	± 0.002%
Temperature effect on output: of reading per °C	± 0.0036%
Temperature effect on zero: of rated output per °F	± 0.002%
Temperature effect on zero: of rated output per °C	± 0.0036%
Excitation voltage, maximum: volts DC or AC rms	20
Insulation resistance, bridge/case: megohms at 50 VDC	>5,000
Number of bridges	1

*Model 2404 output at rated capacity is 1.5 mV/V nominal and bridge resistance 700 ohms.

MODEL 2110-2116

Flanged reaction torque sensors



MODEL 2320 AND 2404

Hollow reaction torque sensors



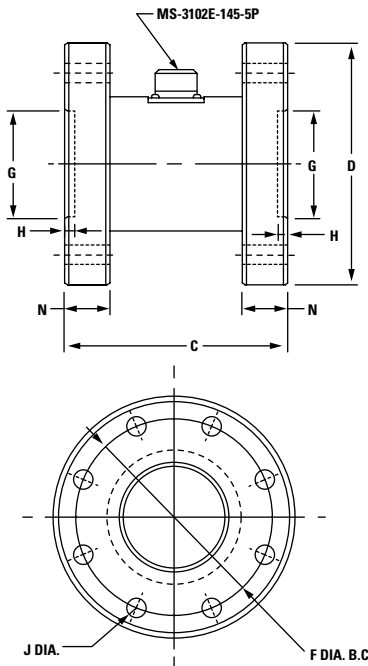

2110-2K, 5K	IN.	CM.
C	3	7.62
D	4	10.16
F	3.25	8.26
G*	1.50	3.81
H	0.13	0.32
N	0.50	1.27
Jt	0.33	0.83

2111-10K, 20K	IN.	CM.
C	3.50	8.89
D	5	12.70
F	4.25	10.80
G*	2.00	5.08
H	0.25	0.64
N	0.75	1.91
Jt	0.39	0.99

2112-50K, 100K	IN.	CM.
C	7.38	18.73
D	8	20.32
F	6.50	16.51
G*	3.50	8.89
H	0.31	0.79
N	1.50	3.81
Jt	0.65	1.63

2113-200K	IN.	CM.
C	8.50	21.59
D	9.75	24.77
F	8	20.32
G*	4	10.16
H	0.31	0.79
N	1.50	3.81
Jt	0.77	1.94

2114-300K±, 500K±	IN.	CM.
C	10.50	26.67
D	14	35.56
F	11	27.94
G*	6	15.24
H	0.31	0.79
N	2	5.08
Jt	1.02	2.59

2115-600K±, 750K±	IN.	CM.
C	10.50	26.67
D	15	38.10
F	12	30.48
G*	6	15.24
H	0.31	0.79
N	2	5.08
Jt	1.52	3.85

2116-1200K±, 2400K±	IN.	CM.
C	16	40.64
D	20	50.80
F	16	40.64
G*	8	20.32
H	0.50	1.27
N	2	5.08
Jt	1.52	3.86

* Diameter tolerance +.002-.000.

† 8 equally spaced holes are located within .005 of true position.

†† 16 equally spaced holes.

± Calibration performed to 300,000 lbs. in. maximum.

2320

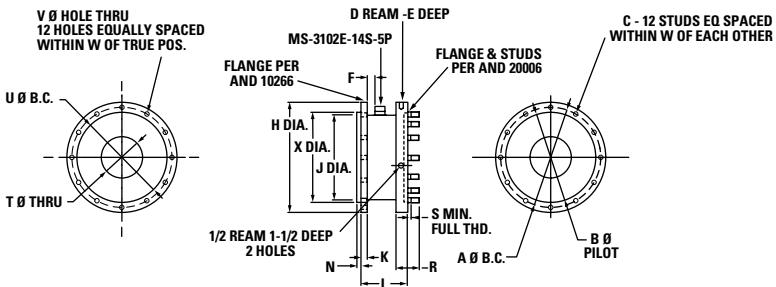

2320	IN.	CM.
A	10	25.40
B	9.00	22.86
C	3/8-24	-
D	0.38	0.94
E	0.38	0.94
F	1.25	3.15
G	0.25	0.64
H	11.00	27.94
J	8.50	21.59
K	0.63	1.58
L	4.25	10.79
N	0.22	0.56
P	1.13	2.85
R	1.13	2.85
S	0.81	2.06
T	4.13	10.47
U	10.00	25.40
V	0.41	1.03
W	0.01	0.02
X	8.99	22.83

2404	IN.	CM.
A	10	25.40
B	6.44	16.35
C	5.00	12.70
D	3.00	7.62
E	30°	30°
F	3/8-24	-
G	0.63	1.59
H	4.13	10.48
J	0.44	0.44
K	0.63	1.58
L	4.12	10.47
N	0.15	0.37
P	2.75	6.98
R	1.28	3.25
S	0.31	0.79
T	-	-
U	-	-
V	-	-
W	-	-
X	-	-

2404

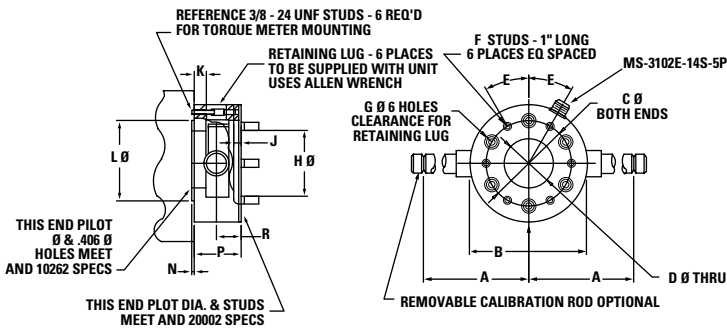

LOAD CARRYING CAPACITY

W = weight of test device

W x S = overhung moment

S = distance to center of gravity of test unit

Do not exceed moment (**W x S**) or shear (**W**), whichever value is attained first. **P** = thrust.

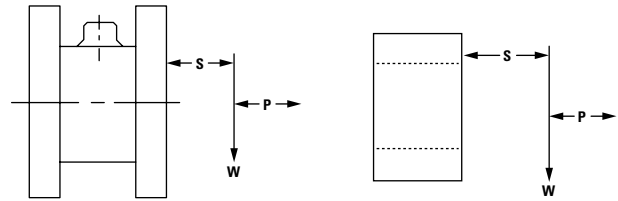

SENSOR CHARACTERISTICS : 2110-2116, 2320 AND 2404

MODEL NUMBER	CAPACITY lbs. in. (N • m)	OVERLOAD lbs. in. (N • m)	TORSIONAL STIFFNESS lbs. in./rad. (N • m/rad.)	MAX. OVERHUNG MOMENT WxS lbs. in. (N • m)	MAX. SHEAR W lbs. (N)	MAX. THRUST P lbs. (N)
2110-2K	2,000 (25)	3,000 (340)	384,000 (43,384)	1,000 (113)	1,500 (6,675)	2,000 (8,895)
2110-5K	5,000 (565)	7,500 (845)	920,000 (103,941)	2,000 (226)	2,000 (8,896)	3,000 (13,344)
2111-10K	10,000 (1,130)	15,000 (1,690)	2,680,000 (302,784)	5,000 (565)	4,000 (17,800)	6,000 (26,688)
2111-20K	20,000 (2,250)	30,000 (3,380)	5,750,000 (649,630)	10,000 (1,130)	6,500 (28,900)	10,000 (44,480)
2111-30K	30,000 (3,390)	45,000 (5,085)	10,000,000 (1,129,790)	15,000 (1,695)	8,500 (3,863)	13,000 (57,824)
2112-50K	50,000 (5,650)	75,000 (8,475)	8,000,000 (903,833)	24,000 (2,704)	12,000 (53,375)	18,000 (80,064)
2112-100K	100,000 (11,300)	150,000 (16,950)	20,000,000 (2,259,584)	50,000 (5,650)	20,000 (89,000)	30,000 (133,440)
2113-200K	200,000 (22,600)	300,000 (33,900)	33,400,000 (3,773,505)	90,000 (10,170)	30,000 (133,440)	40,000 (177,920)
2114-300K	300,000 (33,900)	450,000 (50,850)	60,000,000 (6,778,752)	150,000 (16,950)	42,000 (186,800)	60,000 (266,880)
2114-500K*	500,000 (56,500)	750,000 (84,750)	114,000,000 (12,879,628)	200,000 (22,600)	55,000 (244,640)	80,000 (355,840)
2115-600K*	600,000 (67,796)	900,000 (101,695)	160,000,000 (18,079,096)	200,000 (22,600)	95,000 (422,560)	90,000 (400,320)
2115-750K*	750,000 (84,745)	1,125,000 (127,119)	210,000,000 (23,728,814)	250,000 (28,250)	110,000 (489,280)	105,000 (467,040)
2116-1200K*	1,200,000 (135,593)	1,800,000 (203,375)	180,000,000 (20,338,983)	350,000 (39,550)	140,000 (622,720)	130,000 (578,240)
2116-2400K*	2,400,000 (271,186)	3,600,000 (406,800)	430,000,000 (48,587,570)	700,000 (79,096)	225,000 (1,000,800)	210,000 (934,080)
2404-50	50 (5)	250 (25)	17,000 (1,920)	200 (22)	50 (222)	200 (889)
2404-100	100 (10)	300 (30)	40,000 (4,519)	300 (34)	100 (445)	300 (1,334)
2404-200	200 (20)	500 (55)	100,000 (11,298)	400 (44)	150 (667)	400 (1,779)
2404-500	500 (55)	750 (85)	250,000 (28,245)	700 (77)	300 (1,334)	600 (2,668)
2404-1K	1,000 (115)	1,500 (170)	500,000 (56,490)	1,000 (113)	400 (1,779)	1,000 (4,448)
2404-2K	2,000 (225)	3,000 (340)	1,250,000 (141,224)	2,000 (226)	500 (2,224)	1,500 (6,672)
2404-5K	5,000 (565)	7,500 (850)	3,500,000 (395,427)	3,000 (338)	600 (2,669)	2,500 (11,120)
2320-12K	12,000 (1,350)	18,000 (2,030)	6,000,000 (677,875)	6,000 (676)	1,500 (6,672)	6,000 (26,688)
2320-36K	36,000 (4,050)	54,000 (6,085)	30,000,000 (3,389,376)	15,000 (1,694)	3,000 (13,344)	15,000 (66,720)

*Calibration performed to 300,000 lbs. in.; consult factory for higher calibrations.