

FEATURES :

- Adapts directly to hydraulic cylinder
- Small diameter allows mounting in restricted areas
- High capacities vs. size
- Low deflection

The Lebow® small-diameter, low-cost load cells are designed to be used in applications that require an ability to mount in an existing system with restricted working area. They are commonly used in fluid power transfer systems. Their low cost and ease of mounting allow simultaneous testing of multi-element systems.

They may be directly attached to the piston rod of a hydraulic cylinder. Side-mounted cable connectors allow cable assemblies to be supported without affecting movement of the cell during tension or compression loading.

PERFORMANCE SPECS :**3124 AND 3161**

SPECIFICATIONS	3124	3161
Output at rated capacity: <i>millivolts per volt, nominal</i>	±2	±2
Nonlinearity: <i>of rated output</i>	±0.25%	±0.15%
Hysteresis: <i>of rated output</i>	±0.15%	±0.1%
Repeatability: <i>of rated output</i>	±0.05%	±0.05%
Zero balance: <i>of rated output</i>	±1.0%	±1.0%
Bridge resistance: <i>ohms nominal</i>	350	350
Temperature range, compensated: °F	+70 to +170	+70 to +170
Temperature range, compensated: °C	+21 to +77	+21 to +77
Temperature range, usable: °F	-65 to +200	-65 to +200
Temperature range, usable: °C	-54 to +93	-54 to +93
Temperature effect on output: <i>of reading per °F</i>	±0.002%	±0.003%
Temperature effect on output: <i>of reading per °C</i>	±0.0036%	±0.0054%
Temperature effect on zero: <i>of rated output per °F</i>	±0.002%	±0.002%
Temperature effect on zero: <i>of rated output per °C</i>	±0.0036%	±0.0036%
Excitation voltage, maximum: <i>volts DC or AC rms</i>	20	20
Insulation resistance, bridge/case: <i>megohms at 50 VDC</i>	>5,000	>5,000
Number of bridges:	1 or 2	1 or 2

MODEL 3124

Capacity 5K lbs. to 25K lbs.



Optional dual bridge not shown

MODEL 3161Fatigue resistant
Capacity 2K lbs. to 25K lbs.Fatigue Model 3415 also available,
see page 78.

3124	IN.	CM.
A	4.50	11.43
B	1	2.54
C	0.38	0.97
D	0.81	2.06
E	1.50	3.81
F	1.38	3.51
G	2.44	6.20
H	1.72	4.37

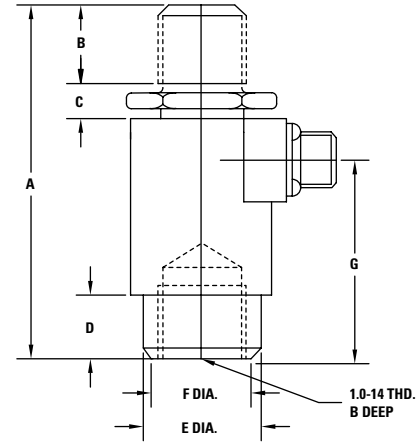
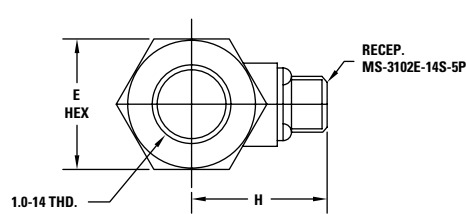

3161	IN.	CM.
A	6.88	17.48
B	1	2.54
C	4.44	11.28
D	1.69	4.29
E	2.38	6.05
F	0.50	1.27
G	1.63	4.14
H	0.25	0.64

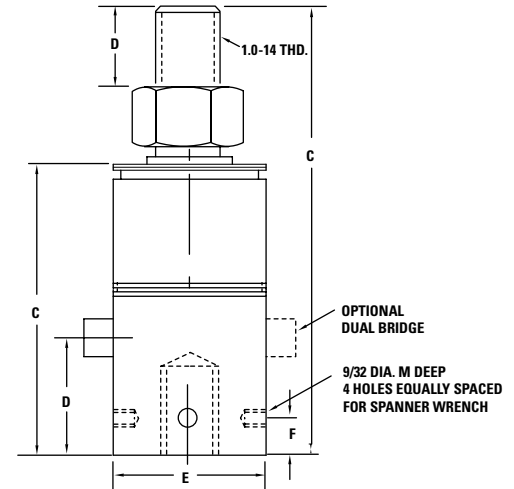
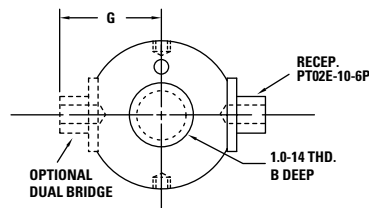

SENSOR CHARACTERISTICS: 3124 AND 3161

MODEL NUMBER	NOMINAL LOAD LIMIT CAPACITY F_z		STATIC OVERLOAD CAPACITY % OF NOM. CAPACITY	FATIGUE CAPACITY % OF NOM. CAPACITY	STATIC EXTRANEIOUS LOAD LIMITS			DEFLECTION AT NOM. LOAD LIMIT INCHES	RINGING FREQUENCY H_z
	LBS.	NEWTONS			SHEAR F_x OR F_y LBS.	BENDING M_x OR M_y LB. INCHES	TORQUE M_z LB. INCHES		
3124	5K	20K	150	n/a	250	750	1,500	0.005	4,600
	10K	50K	150	n/a	250	700	1,100	0.005	6,400
	15K	75K	150	n/a	450	1,300	2,100	0.005	7,700
	20K	100K	150	n/a	650	2,000	3,000	0.005	8,800
	25K	125K	150	n/a	950	2,700	4,500	0.005	9,600
3161	2K	10K	150	100	850	3,800	3,500	0.003	5,000
	5K	20K	150	100	850	3,800	3,500	0.003	6,200
	10K	50K	150	100	850	3,800	3,500	0.003	7,100
	25K	125K	150	100	2,040	6,750	9,600	0.003	11,000

