

MODEL 3270

Tension and compression 100 lbs. to 200,000 lbs.



Models 3272, 3273 and 3274
Capacities 100 lbs. to 20,000 lbs.



Models 3275, 3276 and 3277
Capacities 50,000 lbs. to 200,000 lbs.

**Consult factory
for specials.**

FEATURES :

- 100 lbs. through 200,000 lbs. standard capacities
- Universal tension and compression loading
- Hermetically sealed, glass to metal military style connector IP67 rating
- Heat treated 17-4PH stainless steel
- 10⁷ cycles extended life design, .001" to .003" FS deflection
- Compact package sizes
- 200% FS safe overload capability
- Superior resistance to extraneous loading
- Standardized output of 2mV/V +/-0.25% minimizes test setup
- Built-in wrench flat design provides easy installation
- Available in single, (optional) dual, or (optional) triple bridge configurations
- Metric sizes, special capacities and custom configurations available

The Model 3270 load cell series has been designed to work in harsh environments. These tension/compression load cells are made from 17-4PH stainless steel and are hermetically sealed to an IP67 rating.

The Model 3270 family is designed for demanding applications in automotive, aerospace, agricultural, chemical, military, and paper and pulp markets. The family consists of 12 different capacities from 100 lbs. to 200,000 lbs.

Some of the advantages of these load cells are: small size, high overload capacity, high frequency response, higher stiffness and extended life.

PERFORMANCE SPECS :

3270

SPECIFICATIONS

Output at rated capacity: <i>millivolts per volt</i>	2 ±0.25% *
Maximum nonlinearity error: <i>of full scale output</i>	±0.10%
Maximum hysteresis error: <i>of full scale output</i>	±0.10%
Maximum non-repeatability: <i>of rated output</i>	±0.05%
Zero balance: <i>of rated output</i>	±1.00%
Bridge resistance: <i>ohms</i>	350 and 700**
Excitation voltage, maximum: <i>volts DC or AC rms</i>	20
Temperature range, operating: °F	-65 to +250
Temperature range, compensated: °F	0 to +150
Maximum temperature effect on output: <i>of reading per °F</i>	± 0.002%
Maximum temperature effect on zero: <i>of rated output per °F</i>	± 0.002%
Static overload capacity: <i>of rated capacity</i>	200%

*Model 3272-100 output 1.5mV/V ±0.25%.

**Models 3272 and 3273 are 350 ohms; models 3274, 3275, 3276 and 3277 are 700 ohms.

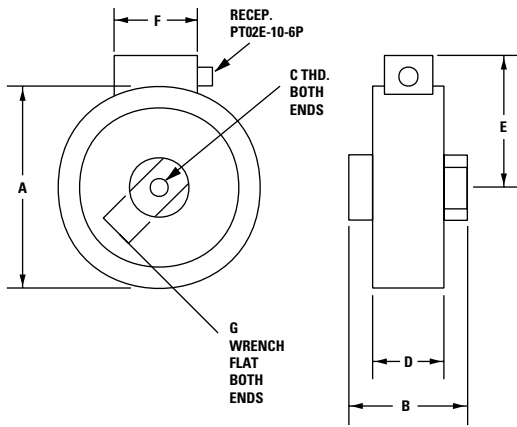

MODEL NUMBER	CAPACITY LBS.	DIMENSIONS						
		A	B	C	D	E	F	G
3272	100-200	2.75	1.50	3/8-24	1.10	2.38	1.75	0.63
3273	500-5K	3.50	2.00	1/2-20	1.45	2.83	1.75	0.88
3274	5K, 10K, 20K	4.50	2.50	1-14	1.56	3.39	1.75	1.50
3275*	50K	6.25	4.25	1 1/2-12	2.97	4.32	1.75	2.13
3276*	100K	7.75	5.00	1 3/4-12	3.52	4.96	1.75	2.50
3277*	200K	9.75	5.75	2 1/4-12	3.93	6.11	1.75	3.25

Dimensions are in inches.

*Has external tension base plate.

SENSOR CHARACTERISTICS: 3270

MODEL NUMBER	NOMINAL LOAD LIMIT CAPACITY F_z		STATIC OVERLOAD CAPACITY % OF NOM. CAPACITY	STATIC EXTRANEIOUS LOAD LIMITS			DEFLECTION AT NOM. LOAD LIMIT INCHES	RINGING FREQUENCY H_z
	LBS.	NEWTONS		SHEAR F_x OR F_y LBS.	BENDING M_x OR M_y LB. INCHES	TORQUE M_z LB. INCHES		
3272	100	500	200	1,300	115	725	0.003	1,200
	200	1K	200	1,900	230	1,000	0.003	1,700
3273	500	2K	200	3,200	550	3,200	0.003	1,900
	1K	5K	200	4,500	1,100	4,500	0.003	2,700
	2K	10K	200	8,300	2,200	8,200	0.003	3,900
	5K	20K	200	13,000	2,700	10,900	0.003	6,100
3274	5K	20K	200	7,200	7,400	10,000	0.002	5,100
	10K	50K	200	14,500	14,800	18,400	0.002	7,200
	20K	100K	200	34,600	29,700	39,800	0.002	10,100
3275	50K	200K	200	39,000	39,000	54,000	0.001	11,700
3276	100K	500K	200	78,000	92,000	123,000	0.001	12,200
3277	200K	1M	200	118,000	222,000	296,000	0.001	12,700