

## MODEL 3691



Capacities available 1K to 10K lbs.

## MODEL 3674



Capacities available 5K to 50K lbs.

## MODEL 3603 AND 3644



Model 3603—Capacities available 100K to 500K lbs.  
Model 3644—Capacity available 1,000K lbs.

### FEATURES :

- Inexpensive
- Built-in load button
- Compact size
- Minimum deflection

The compression only load cells were developed by our engineers to deliver a high degree of performance at low cost and low deflection.

These designs handle a full range of compression loads including press calibration, weighing tube mills, extruding processes and rolling and reduction mills.

Consult factory for alternative compression button style load cells.

### PERFORMANCE SPECS :

#### 3603, 3644, 3674 AND 3691

SPECIFICATIONS	3603 & 3644	3674	3691
<b>Output at rated capacity:</b> <i>millivolts per volt, nominal</i>	2	2	1.8
<b>Nonlinearity:</b> <i>of rated output</i>	± 0.15%	± 0.15%	± 1.0%
<b>Hysteresis:</b> <i>of rated output</i>	± 0.15%	± 0.10%	± 1.0%
<b>Repeatability:</b> <i>of rated output</i>	± 0.05%	± 0.03%	± 0.5%
<b>Zero balance:</b> <i>of rated output</i>	± 2.0%	± 2.0%	± 0.5%
<b>Bridge resistance:</b> <i>ohms nominal</i>	350	350	350
<b>Temperature range, compensated:</b> °F	+70 to +170	+70 to +170	+70 to +170
<b>Temperature range, compensated:</b> °C	+21 to +77	+21 to +77	+21 to +77
<b>Temperature range, usable:</b> °F	-65 to +200	-65 to +200	-65 to +200
<b>Temperature range, usable:</b> °C	-54 to +93	-54 to +93	-54 to +93
<b>Temperature effect on output:</b> <i>of reading per °F</i>	± 0.002%	± 0.002%	± 0.005%
<b>Temperature effect on output:</b> <i>of reading per °C</i>	± 0.0036%	± 0.0036%	± 0.009%
<b>Temperature effect on zero:</b> <i>of rated output per °F</i>	± 0.002%	± 0.002%	± 0.005%
<b>Temperature effect on zero:</b> <i>of rated output per °C</i>	± 0.0036%	± 0.0036%	± 0.009%
<b>Excitation voltage, maximum:</b> <i>volts DC or AC rms</i>	20	20	15
<b>Insulation resistance, bridge/case:</b> <i>megohms at 50 VDC</i>	>5,000	>5,000	>5,000
<b>Number of bridges:</b>	1 or 2	1 or 2	1

Consult factory for Model 3630 (1K-10K lbs. capacities) button cells.



3603	IN.	CM.
A	7	17.78
B	5.25	13.34
C	3.50	8.89
D	3.88	9.86
E	0.13	0.33

3644	IN.	CM.
A	11	27.94
B	7.50	19.05
C	5.50	13.97
D	5.12	13
E	0.13	0.33

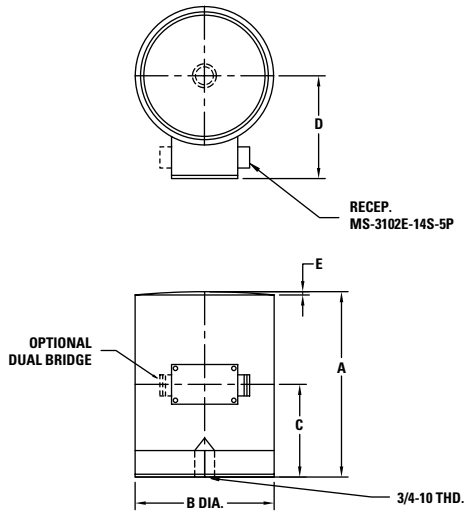
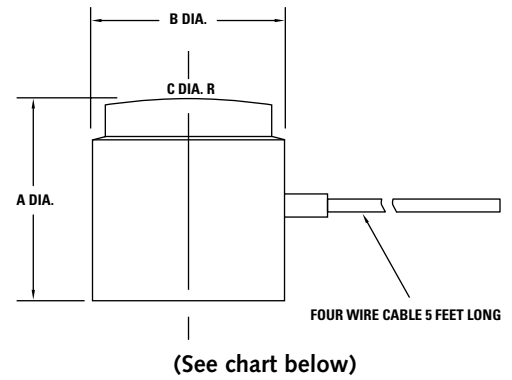
**MODEL 3691**

3674	IN.	CM.
A	3.50	8.89
B	2.38	6.05
C	1	2.54
D	0.13	0.33
E	0.11	0.28
F	1.33	3.38
G	0.58	1.47
H	1.61	4.09
J	0.50	1.27
K	0.25	0.64
L	0.75	1.91

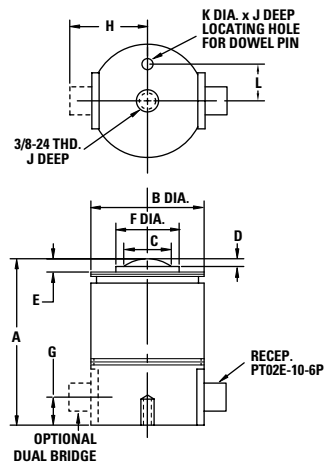
**SENSOR CHARACTERISTICS : 3603, 3644, 3674 AND 3691**

MODEL NUMBER	NOMINAL LOAD LIMIT CAPACITY F <sub>z</sub>		STATIC OVERLOAD CAPACITY % OF NOM. CAPACITY	DEFLECTION AT NOM. LOAD LIMIT INCHES	RINGING FREQUENCY Hz	A	B	C RADIUS
	LBS.	NEWTONS						
3691-1K	1K	5K	120	0.003	16,000	0.63	0.60	1.65
3691-2K	2K	10K	120	0.003	16,000	0.63	0.60	1.65
3691-5K	5K	20K	120	0.003	16,000	0.88	0.88	1.65
3691-7.5K	7.5K	35K	120	0.003	16,000	0.88	0.88	1.65
3691-10K	10K	50K	120	0.003	16,000	0.88	0.88	1.65
3674	5K	20K	150	0.003	5,000			
	10K	50K	150	0.003	7,000			
	20K	100K	150	0.003	9,000			
	50K	200K	150	0.003	11,000			
3603	100K	500K	150	0.008	3,800			
	200K	1M	150	0.008	5,800			
	300K	1.5M	150	0.008	6,000			
	500K	2M	150	0.008	7,000			
3644	1,000K	5M	150	0.011	10,000			