

# ADW-FFW Fast Fill by Weight Systems



## Introduction

This application is to control high speed, high accuracy filling by weight. Either in a stand alone mode or in conjunction with a PLC.

Operation:

On receipt of the start fill signal weightment is auto tared, and the relay contacts for fast and slow speed are closed, The system is optimised by a routine to ensure that, fast feed is held as long as possible. In-flight

compensation is applied to the slow feed and automatically adjusted to minimise final error. When pre set values are reached, contacts turn off the fast and slow feeds.

The 'weight' complete signal is given when within pre selected setting values and time Auto Tare will take place only when the value falls within the pre set auto tare band.

## Features

- Fast & accurate fill control
- Fast 10mS update input
- Fast & slow feeds
- System speed optimisation
- Auto tare
- Auto calibration
- Auto 'In Flight ' compensation
- Weight complete output
- Stand alone or control with PLC
- Options for: Printer
- Communications 10 x Fill selections switching
- Totaliser output

## Operating Instructions for Fast Fill Weighing Systems ADW-FFW

Code	Value	Display Range	Description
rEC	-	1 to 10	Current fill selectable (recipe) if available
Pass	-	1111	Password (customer select as standard optional extra)
tsp	Eng terms	± 19,999	Target Set Point
diF	Eng terms	± 19,999	Default In Flight (on slow feed)
FSP*	Eng terms	0 to 19,999	Fast Feed Set Point
*Selected for current fill (recipe).			
ot	-	0.0 to 25.5	Optimisation time (target slow feed)
IFS	-	0 - 25	Number of In Flight error samples
IFP	%	0 - 100	In Flight Gain adjustment
OtP	%	0 - 100	Gain of Fast Feed Setpoint
SEtb	Eng terms	± 19,999	Settle band for scale steady
St	Seconds	0-25.5	Scale steady settle time
Std	Seconds	0-25.5	Start delay for start contact to Fast & Slow feed output energising
POdF	Division	0-19999	Divides totalised pulse output by value set Pulse output duration, sets the mark/
POd	m Seconds	1-255	space ratio of pulse output
Atb	Eng terms	0-19,999	Auto Tare Band
ISP	Eng terms	±19999	Intermediate Setpoint
CALL	Eng terms	± 19,999	Low Calibration value
CALH	Eng terms	± 19,999	High Calibration value
dA	-	0 to 7	Display Averaging + Display freeze at weightment complete (7 = 10mS update)
	-	8 to 31	Display Averaging with no Display freeze function on weightment complete
	-	16 or Greater	Sets a NON Latching Intermediate Set Point
dP	-	0 to 5	Decimal Point position
CP	-	0 to 129	Comms Protocol
	-	0 - 127 Printer	
	-	128 Fast Format	
	-	MANTRABUS	
SDST/Lab	-	129 ASCII	
	-	0 - 254	Selects serial device station number or label type for printer
Ln	-	0 - 19,999	Log number for printer
rS	-	0 - 255	Set Display resolution

## Input Details

Calibration	Automatic digital by use of keypad and 1 (or 2) known weights. Manual calibration can also be selected
Sensitivity	Preset via DIL switches between 0.5 to 200mV/V
Excitation	10V dc nominal, 150mA maximum
Compensation	By $\pm$ sense wires to compensate for cable, connection volt drops and any variation in 10V supply
Accuracy	90 days $\pm$ 0.08% of reading $\pm$ 0.05% of FSD typical
Drift	0.002%/°C typical @ 2.5mV/V
Input Filter	Programmable to average up to 64 display updates

## Output Details

### The Relay Module (REM4)

The module consists of 4 relays rated at 230 volts 5 Amps - SPCO, DIN rail mounted for a G or top hat profile. Each relay is pluggable and connections are made by 12.5mm field screw terminals. Indication of relay status is shown by LED's. The module can be situated up to 2 metres from the ADW Strain Gauge Controller.

### Totaliser

Fast pulse for electronic counter output of 1 pulse per digit of 'Bagged' material.  
 ADW-FFW Pulse Output  
 5V CMOS output protected.  
 By 1K resistor  
 Pulse width = 300mS negative going

### Communications & Printer Port

20mA, RS485, RS232 set for Comms or Printer Port.

### Power Supplies

Code	Type	
W240	230V	AC 50-60Hz 10W
W110	115V	AC 50-60Hz 10W
W12/24	9-32V	12 & 24V DC 10W isolated
W24/48	18-60V	24 & 48V DC 10W isolated

### Data Retention/Protection

Retention: 10 years for set up values, minimum of 100,000 write cycles.  
 Protection of data and function(s): Watchdog timer giving repeat auto resets. Impending power failure detection and hold off. Keypad security and time out.

### CE & Environmental

Storage temperature	-20 to +70°C
Operating temperature	-10 to 50°C
Relative humidity	95% maximum non stop condensing
Safety/Low Voltage Directive	73/23/EEC amended by 93/68/EEC To IEC 1010-1:1990, EN 61010 - 1 - 1993
EMC Directive	89/336/EEC
Emissions	EN 50 081 - 1 : 1992 (Light Industrial) EN 50 081 - 2 : 1992 (Heavy Industrial) pr EN 50 093 : 1991
EMC Immunity	EN 50 082 - 1 : 1992 (Light Industrial) EN 50 082 - 2 : 1992 (Heavy Industrial)

### Physical

Case Dimensions	DIN 72 x 72 x 163mm (excluding mounting terminal)
Case Material	Grey Noryl, flame retardant
Weight	750g
Terminals	2.5mm, saddle field terminals
Accessibility	All electronics removable through front panel leaving field wiring and case in situ.

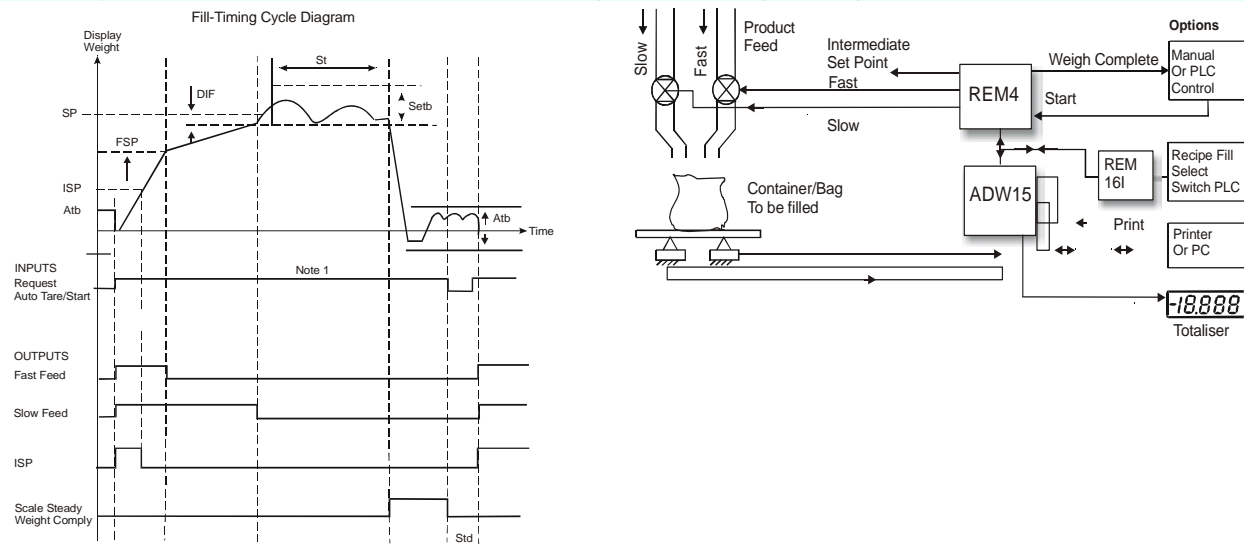

Note 1: If the START input is released before filling is complete, the fill cycle is aborted



Dunston House, Dunston Road, Chesterfield, Derbys, S41 9QD  
 Tel: 01246 260250 Fax: 01246 260955  
 e-mail: sales@amberinstruments.com web: www.amberinstruments.com

Torque Transducers, Load Cells (general purpose, weighing & fatigue rated). Multi-Axis Force/Torque, Weighing Instruments, Process Instruments, Portable Data Loggers, Pressure Sensors, Proximity Sensors, Laser (Distance Measuring) Sensors, & more.