

Amber Instruments Ltd

Shaft Driven Slip Ring Torque Sensors T360, T361, T362, T363, T364



T360-STD-2K

- Capacities from 150 to 500K lb-in
- High stiffness and low inertia
- Compatible with AC or DC electronics
- Internal zero velocity speed sensor (optional)
- SAE 4340 alloy steel construction with satin nickel finish
- Supplied with mating connector

The T360 Series slip ring torque sensors were designed for the measurement of viscosity and for in-line testing of motors, engines, transmissions, propellers, pumps, drivelines, and similar rotating devices. The T360 Series has 20% to 40% greater stiffness, has 4 to 6 times less rotating inertia, and is 1/3 the size of comparable models available from other suppliers. The slip ring allows the use of either AC carrier or DC strain gage signal conditioning electronics. The optional zero velocity speed sensor is installed inside the T360 Series housing. Interconnecting cable assemblies are available as an option. SensorData will provide in-house calibration of the T360 Series with customer-supplied electronics for a fee.

Specifications

(Subject to change without notice)

Rated Capacity	150, 300, 500, 1K, 2K, 3K, 5K, 10K, 20K, 50K, 100K, 200K, 500K lb-in
Rated Speed	6,500 (T360, T361, T362), 5,600 (T363), 4,800 (T364) rpm
Nonlinearity	0.05% of rated output
Hysteresis	0.05% of rated output
Nonrepeatability	0.02% of rated output
Rated Output, bridge, typical	2 mV/V
Zero Balance	+/-0.5% of rated output
Temperature Range, operating	-20 to +200 F
Temperature Range, compensated	+68 to +170 F
Temperature Effect on Output	0.001% of load/F
Temperature Effect on Zero	0.001% of rated output/F
Bridge Resistance, typical	350 ohms
Excitation Voltage, bridge, typical	10 VDC or VAC rms
Excitation Voltage, bridge, maximum ⁽¹⁾	20 VDC or VAC rms
Insulation Resistance, bridge to case	>5000 megohms at 50 VDC
Input voltage, speed sensor, V _{cc} (optional) ⁽²⁾	4.5 to 24 VDC
Maximum Load, safe ⁽³⁾	200% of rated capacity
Maximum Load, ultimate ⁽⁴⁾	400% of rated capacity
Number of Bridges	1
Weight	5.5 lb (T360), 11 lb (T361), 17.5 lb (T362), 25 lb (T363), 38 lb (T364), add 1 lb for i200
Construction	SAE 4340 alloy steel with satin nickel finish

⁽¹⁾ Temperature gradients caused by higher excitation voltages may effect performance.

⁽²⁾ Output is an open collector NPN with internal 4.7K ohm pull up resistor.

⁽³⁾ With load centered, maximum torque that can be applied without producing a permanent shift in performance characteristics.

⁽⁴⁾ With load centered, maximum torque that can be applied without physical damage.

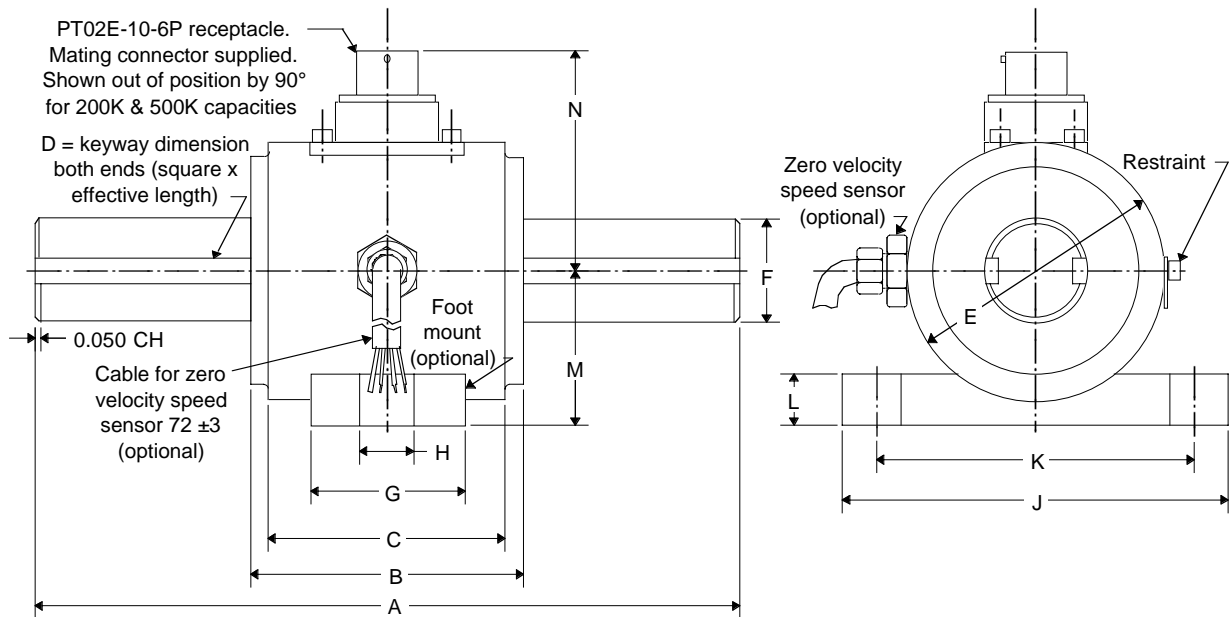

Mod	Capacity lb-in	A in	B in	C in	D in (± 0.001) Sq x Eff Lngth	E in	F in	G in	H in	J in	K in	L in	M in	N in
T360	150 thru 3K	6.85	2.65	2.30	0.250 x 2.00	2.50	1.001/0.999	1.50	0.375	3.75	3.12	0.375	1.500	2.32
T361	5K thru 20K	7.50	3.00	2.30	0.312 x 2.37	3.18	1.574/1.572	1.50	0.375	3.75	3.12	0.375	1.825	2.58
T362	50K	8.00	3.00	2.30	0.375 x 2.62	3.80	2.165/2.163	1.50	0.375	3.75	3.12	0.375	2.150	2.78
T363	100K	10.00	4.00	3.50	0.500 x 3.00	5.50	2.755/2.753	2.50	0.500	6.75	5.62	0.625	3.250	3.75
T364	200K, 500K	12.00	5.75	4.50	1.000 x 3.00	8.00	4.724/4.722	3.50	0.625	7.75	6.62	0.750	3.750	4.25

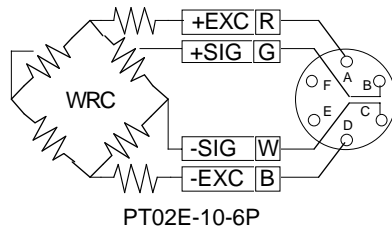
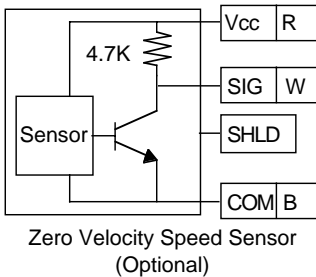

Model	Capacity lb-in	Torsional Stiffness lb-in/rad	Rotating Inertia lb-in-sec ²
T360	150 thru 3K	0.26×10^6	2.11×10^{-3}
T361	5K thru 20K	1.20×10^6	6.23×10^{-3}
T362	50K	3.65×10^6	3.56×10^{-2}
T363	100K	8.11×10^6	0.127
T364	200K, 500K	14.87×10^6	0.160

If the T360, T361, T362, T363, or T364 are supplied with optional SensorData i200 AC carrier strain gage conditioning electronics, the i200 instruction manual or data sheet should be referred to for wiring information and specifications.

ORDERING INFORMATION

- T36X-STD-Capacity Standard with receptacle and mating connector.
- T36X-STD-Capacity-A Same as T36X-STD-Capacity except supplied with SensorData i200 strain gage conditioning electronics.
- T36X-STD-Capacity-S Same as T36X-STD-Capacity except supplied with zero velocity speed sensor.
- T36X-STD-Capacity-S-A Same as T36X-STD-Capacity except with zero velocity speed sensor & i200 strain gage conditioning electronics.
- Foot Mount Option Replace STD with 105 in above model designations; e.g., T360-105-Capacity-S-A.
- Cable Assembly Optional; 10 ft., color coded, shielded, mating connector sensor end, customer specified connector instrument end.
- Cable Assembly Note Optional; 10 ft., color coded, shielded, mating connector sensor end, leads stripped and tinned instrument end.
- Note Mounting hardware is optional and not included unless specified at time of order.

IMPORTANT NOTICE

Dimensions above are in inches unless otherwise noted. Manufacturer not responsible for any modification to product, fixtures, or accessories made by user or third party. User should request certified drawings before designing mountings or fixtures. Manufacturer reserves right to modify or change design, dimensions, specifications, and features of this product without prior written notice. Changes to NOTICE must be in writing and accepted by manufacturer.



Dunston House, Dunston Road, Chesterfield, Derbys, S41 9QD
 Tel: 01246 260250 Fax: 01246 260955
 e-mail: sales@amberinstruments.com web: www.amberinstruments.com

Torque Transducers, Load Cells (general purpose, weighing & fatigue rated). Multi-Axis Force/Torque, Weighing Instruments, Process Instruments, Portable Data Loggers, Pressure Sensors, Proximity Sensors, Laser (Distance Measuring) Sensors, & more.