

Amber Instruments Ltd

Low Capacity Shaft Driven Transformer Coupled Torque Sensor Model T260



T260 Rotary Transformer Torque Sensor with i200 AC Carrier Strain Gage Signal Conditioning Electronics

- *Non-contact measurement of torque*
- *High stiffness and low inertia*
- *On-board shunt calibration circuit*
- *Rated speed 20,000 rpm (35,000 rpm optional)*
- *Internal zero velocity speed sensor (optional)*
- *SAE 4340 alloy steel construction with satin nickel finish*

The T260 rotary transformer coupled torque sensor was designed for the measurement of viscosity and for in-line testing of motors, engines, transmissions, propellers, pumps, drivelines, and similar rotating devices. The T260 has 20% to 40% greater stiffness, has 4 to 6 times less rotating inertia, and is 1/3 the size of comparable models available from other suppliers. The T260 requires the use of AC carrier strain gage signal conditioning electronics such as SensorData's i200. The optional zero velocity speed sensor is installed inside the T260 housing. Interconnecting cable assemblies are available as an option. SensorData will provide in-house calibration of the T260 with customer-supplied electronics for a fee.

Specifications

(Subject to change without notice)

Rated Capacity	100, 200, 500, 1K, 2K lb-in
Rated Speed	20,000 rpm (35,000 rpm optional)
Nonlinearity	0.05% of rated output
Hysteresis	0.05% of rated output
Nonrepeatability	0.02% of rated output
Rated Output, bridge, typical	2 mV/V
Zero Balance	+/-0.5% of rated output
Temperature Range, operating	-20 to +200 F
Temperature Range, compensated	+68 to +170 F
Temperature Effect on Output	0.001% of load/F
Temperature Effect on Zero	0.001% of rated output/F
Bridge Resistance, typical	350 ohms
Excitation	2.8 to 5 VAC rms, 3 kHz to 5 kHz
Insulation Resistance, bridge to case	>5000 megohms at 50 VDC
Input voltage, speed sensor, V _{cc} (optional) ⁽¹⁾	4.5 to 24 VDC
Maximum Load, safe ⁽²⁾	200% of rated capacity
Maximum Load, ultimate ⁽³⁾	400% of rated capacity
Number of Bridges	1
Weight	4 lb without i200, 5 lb with i200
Construction	SAE 4340 alloy steel with satin nickel finish

⁽¹⁾ Output is an open collector NPN with internal 4.7K ohm pull up resistor

⁽²⁾ With load centered, maximum torque that can be applied without producing a permanent shift in performance characteristics.

⁽³⁾ With load centered, maximum torque that can be applied without physical damage.

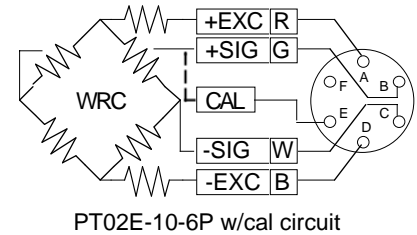
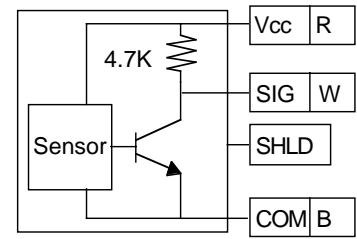
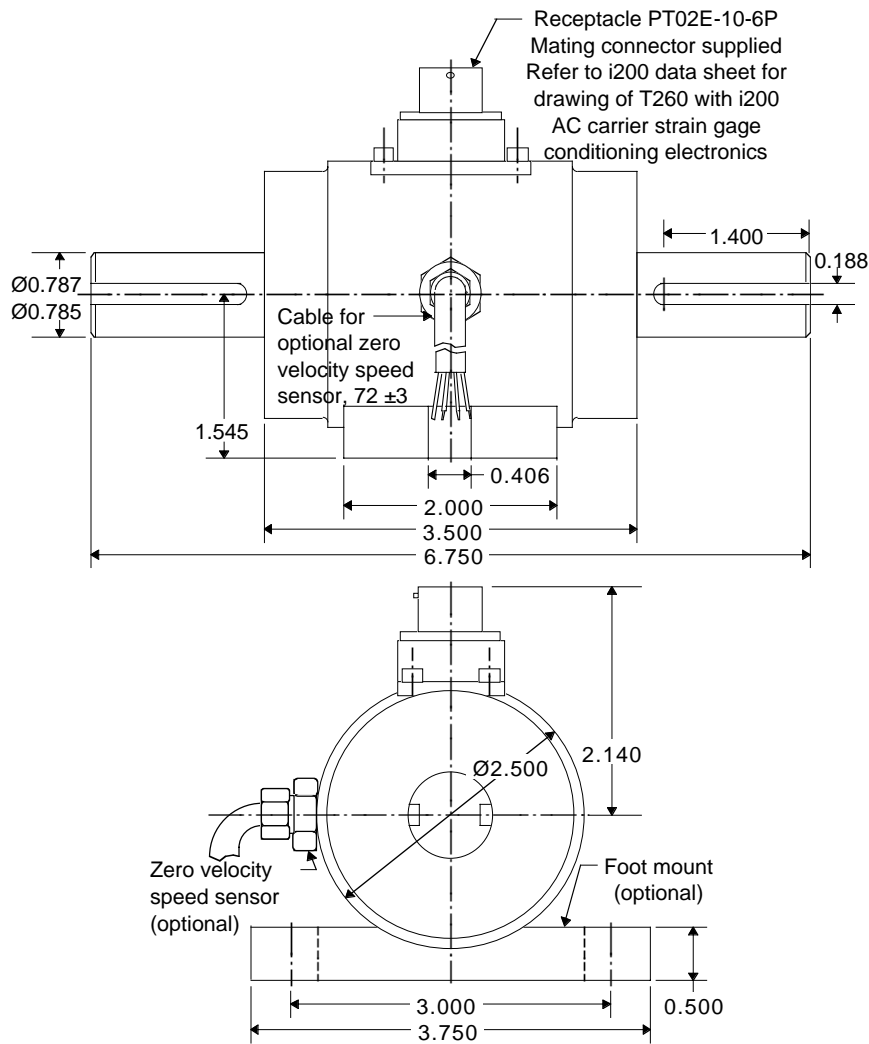

Capacity lb-in	Torsional Stiffness lb-in/rad	Rotating Inertia lb-in-sec ²
100	34 x 10 ⁻³	6.6 x 10 ⁻⁴
200	39 x 10 ⁻³	6.6 x 10 ⁻⁴
500	54 x 10 ⁻³	6.6 x 10 ⁻⁴
1K	85 x 10 ⁻³	6.6 x 10 ⁻⁴
2K	95 x 10 ⁻³	6.6 x 10 ⁻⁴

NOTE

If the T260 is supplied with the optional SensorData i200 AC carrier strain gage conditioning electronics, the i200 instruction manual or data sheet should be referred to for wiring information and specifications.

ORDERING INFORMATION

T260-STD-Capacity	Standard with receptacle and mating connector.
T260-STD-Capacity-A	Same as T260-STD-Capacity except supplied with SensorData i200 strain gage conditioning electronics.
T260-STD-Capacity-S	Same as T260-STD-Capacity except supplied with zero velocity speed sensor.
T260-STD-Capacity-S-A	Same as T260-STD-Capacity except with zero velocity speed sensor & i200 strain gage conditioning electronics.
Foot Mount Option	Replace STD with 105 in above model designations; e.g., T260-105-Capacity-S-A
35,000 RPM Option	Replace STD with 111 in above model designations; e.g., T260-111-Capacity-S-A. Not available with foot mount.
Cable Assembly	Optional; 10 ft., color coded, shielded, mating connector sensor end, customer specified connector instrument end.
Cable Assembly	Optional; 10 ft., color coded, shielded, mating connector sensor end, leads stripped and tinned instrument end.
Note	Mounting hardware is optional and not included unless specified at time of order

IMPORTANT NOTICE

Dimensions above are in inches unless otherwise noted. Manufacturer not responsible for any modification to product, fixtures, or accessories made by user or third party. User should request certified drawings before designing mountings or fixtures. Manufacturer reserves right to modify or change design, dimensions, specifications, and features of this product without prior written notice. Changes to NOTICE must be in writing and accepted by manufacturer.



Dunston House, Dunston Road, Chesterfield, Derbys, S41 9QD
Tel: 01246 260250 Fax: 01246 260955
e-mail: sales@amberinstruments.com web: www.amberinstruments.com

Torque Transducers, Load Cells (general purpose, weighing & fatigue rated). Multi-Axis Force/Torque, Weighing Instruments, Process Instruments, Portable Data Loggers, Pressure Sensors, Proximity Sensors, Laser (Distance Measuring) Sensors, & more.